



Air Starters

SS175/SS350 Series



For engine displacement of: Diesel—200 to 1200 CID (3 to 20 liters)
Carburated—400 to 2400 CID (6 to 40 liters)

Features/Benefits

- Sealed for use in air or gas applications
- Rugged 36 hp motor on SS350;
18 hp motor on SS175
- Overhung pre-engaged pinion design
for fit-up flexibility
- Backcap ports for injection lubricating

Versatile

- Left- and right-hand rotation available
- 4 inlet, 4 exhaust, and 12 housing
orientations
- 90-150 psi operation
- Compact, lightweight design makes
installation easier
- SAE01 and SAE03 flanges fit most
worldwide manufacturers' engines



The SS350GE03R29 starter is mounted on a Cummins M14TA to be used as a marine generator set.



Air Starters

SS175G DIMENSIONS

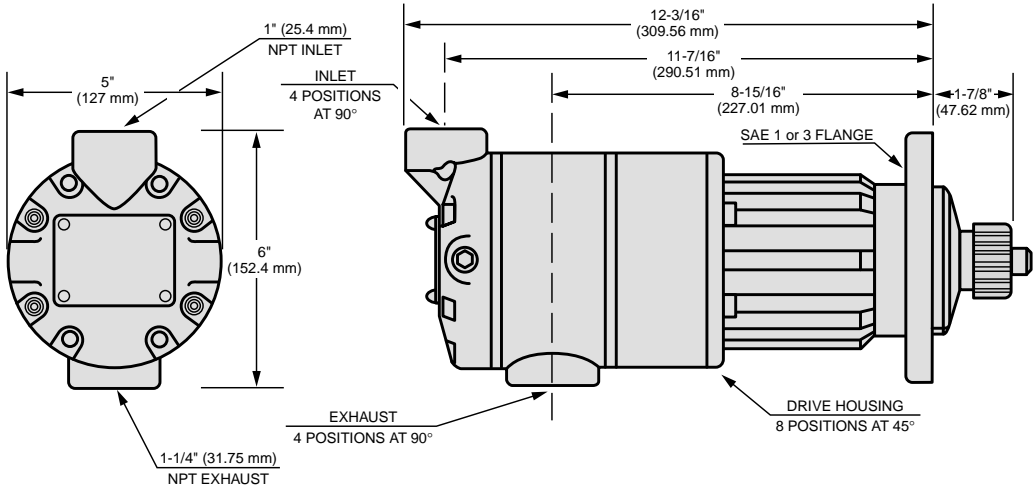

	Weight lbs (kg)
SS175G	29 (13.2)



SS350G DIMENSIONS

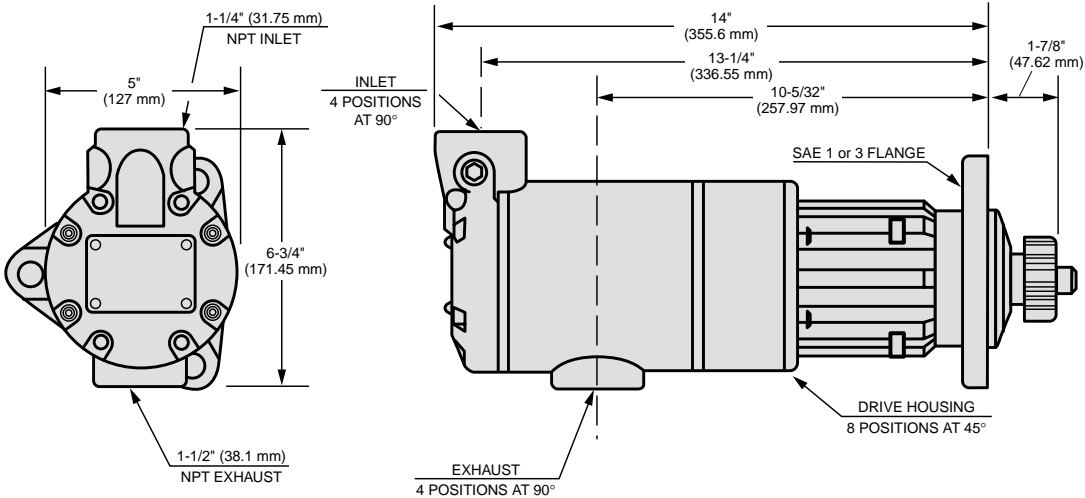

	Weight lbs (kg)
SS350G	33 (15.0)



SS175/SS350 Series

SS175 Performance Information

Pressure PSI (bar)	Breakaway Torque ft-lb (Nm)		Speed @ Max HP RPM		Max HP	Flow @ Max HP SCFM (L/s)
	B Ratio	E Ratio	B Ratio	E Ratio		
90 (6.2)	30 (41)	42 (57)	3500	2500	10	300 (142)
120 (8.3)	38 (51)	54 (73)	3800	2700	14	400 (189)
150 (10.3)	46 (62)	70 (95)	4100	2800	18	500 (236)

SS350 Performance Information

Pressure PSI (bar)	Breakaway Torque ft-lb (Nm)		Speed @ Max HP RPM		Max HP	Flow @ Max HP SCFM (L/s)
	B Ratio	E Ratio	B Ratio	E Ratio		
90 (6.2)	70 (95)	100 (136)	2900	2000	19	525 (248)
120 (8.3)	90 (122)	130 (176)	3100	2200	27	750 (354)
150 (10.3)	110 (149)	160 (217)	3400	2400	36	900 (425)

SS175 Number of Starts per Tank

(Assuming 1-Second Crank Time @ 90 PSI)

Max Tank Pressure (psi)	300	17	26	35	44	52	61	70	79	20	Max Tank Pressure (bar)
	270	15	23	31	38	46	53	61	69	18	
	240	13	20	26	33	39	46	52	59	16	
	210	11	16	22	27	33	38	44	49	14	
	180	9	13	17	22	26	31	35	39	12	
	150	7	10	13	16	20	23	26	29	10	
	120	4	7	9	11	13	15	17	20	8	
	90	2	3	4	5	7	8	9	10	6	
		40	60	80	100	120	140	160	180		
		151	227	302	378	454	529	605	680		
	Tank Size									Gallons Liters	

SS350 Number of Starts per Tank





(Assuming 1-Second Crank Time @ 90 PSI)

Max Tank Pressure (psi)	300	10	15	20	25	30	35	40	45	20	Max Tank Pressure (bar)
	270	9	13	17	22	26	31	35	39	18	
	240	7	11	15	19	22	26	30	34	16	
	210	6	9	12	16	19	22	25	28	14	
	180	5	7	10	12	15	17	20	22	12	
	150	4	6	7	9	11	13	15	17	10	
	120	2	4	5	6	7	9	10	11	8	
	90	1	2	2	3	4	4	5	6	6	
		40	60	80	100	120	140	160	180		
		151	227	302	378	454	529	605	680		
	Tank Size									Gallons Liters	

Air Starters

SS175/350 Series Accessories

See catalog pages I-1 to I-20 for detailed Accessory information.

IR Part #	Description	Picture
1 SS350-A674	1 1/2" Muffler	
2 150BM-A674	1-1/4" Muffler	
3 150BMP-1051B	1/4" 12 V Solenoid Valve	
4 150BMP-2451B	1/4" 24 V Solenoid Valve	
5 NL-24-8	In-Line Lubricator	
6 HDL2 (Stationary)	3/8" NPT Lubricator (1.3 cc)	
7 HDL3 (Transportation)	3/8" NPT Lubricator (0.4 cc)	
8 SMB-618	Push Button Valve	
9 SMB-G618	Push Button Valve For Natural Gas Operation	

IR Part #	Description	Picture
10 SRV125T	1-1/4" Relay Valve For Vehicular Applications	
11 SRV125	1-1/4" Relay Valve For Stationary Applications	
12 SRV150SS	1-1/2" Gas Rated Relay Valve	
13 150BMP-1058	Gladhand	
14 150BMP-1064	1/8", 150 psi Pressure Gauge	
15 ST900-267-24	1-1/2" Strainer (300 Mesh)	
16 ST900-266-24	1-1/2" Strainer Element (300 Mesh)	
17 150BM-A735	1-1/4" Road Splash Deflector	
18 SS350-A735	1-1/2" Road Splash Deflector	
19 150BMP-1056	1/2" Check Valve	

Red item numbers correspond to numbers in diagrams on page E-5.

SS175/SS350 Series

SS175/SS350 Stationary Installation

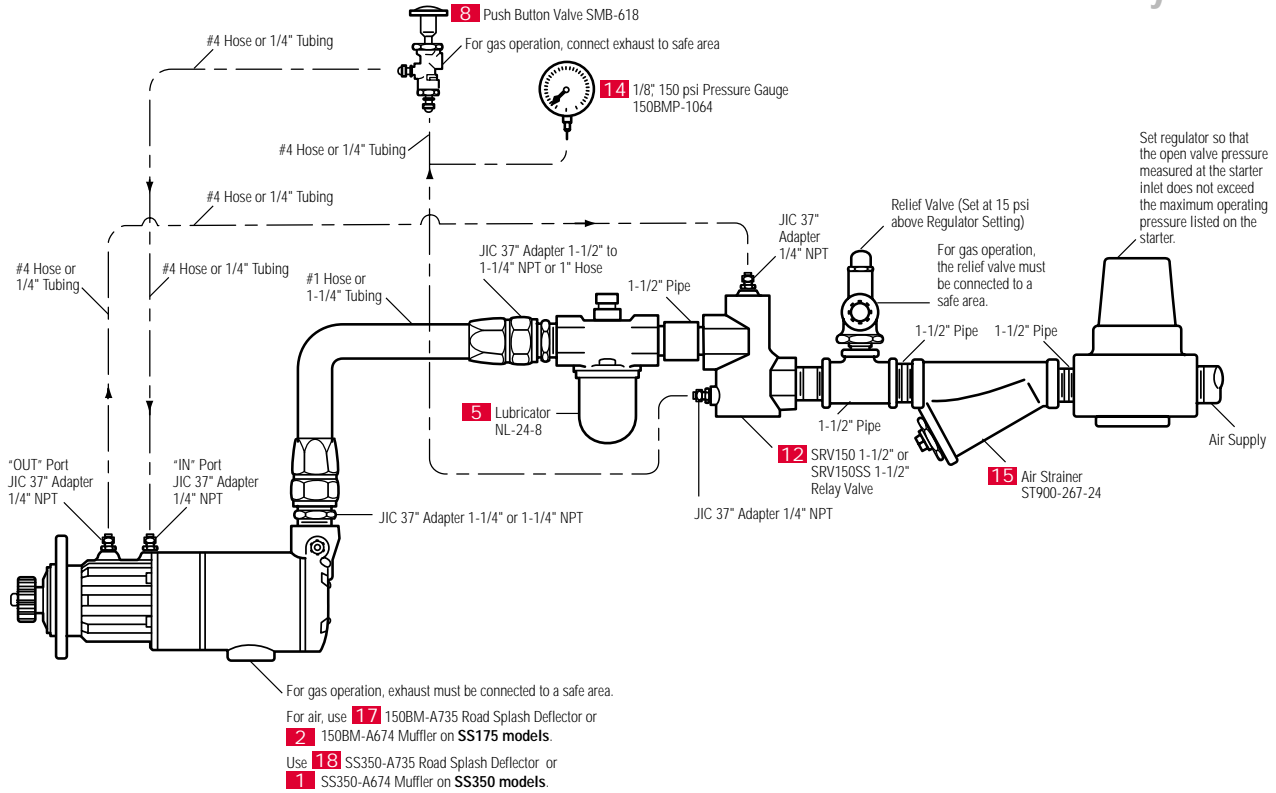

SS175/SS350 Typical Vehicular Installation

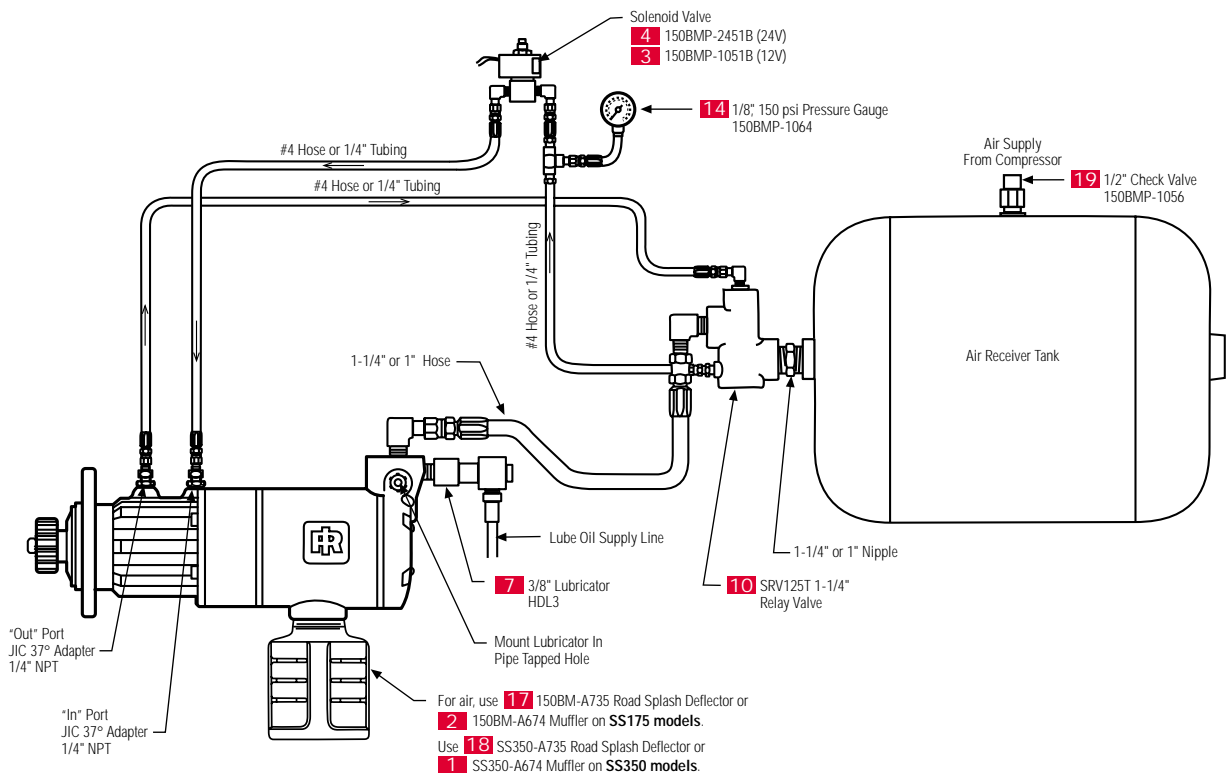

SS175 Crossover Model Numbers

SS175 Available Units	Obsolete Units
SS175GB01L-00A	
SS175GB01L-02J	
SS175GB01R071-02J	
SS175GB01R15-02J	5BMGA12RH-3F
SS175GB01R77-02J	5BMGA56RH-49F
SS175GB01R81-02J	
SS175GB01R85-02J	
SS175GB03L-01E	
SS175GB03R15-02H	
SS175GB03R31-02H	
SS175GB03R77-02H	
SS175GE01L30-02J	
SS175GE01R15-02J	
SS175GE01R21-02J	
SS175GE01R29-02J	5BMGA12RH-5F
SS175GE01R77-02J	
SS175GE01R85-02J	5BMGA56RH-52F
SS175GE01R99-00D	
SS175GE01R99-03I	
SS175GE03L16-02H	
SS175GE03L30-02H	
SS175GE03L32-02H	
SS175GE03R29-02F	
SS175GE03R29-02H	5BMGA11RH-2
SS175GE03R29-03G	
SS175GE03R31-02H	
SS175GE03R37-02H	
SS175GE03R25-02H	5BMGA11RH-1

SS350 Crossover Model Numbers

SS350 Available Units	Obsolete Units
SS350GB01L30-02J	
SS350GB01R29-02J	
SS350GB01R77SR-02J	
SS350GB01R85-02H	
SS350GB01R85-02J	150BMPAB01R85
SS350GB01R99-00D	
SS350GB03R29-02H	
SS350GB03R29SR-02H	
SS350GB03R29SR-03I	
SS350GB03R31-02H	
SS350GB03R77-02H	150BMPAB0377
SS350GB03R85-02H	150BMPAC03R77
SS350GE01R15-02H	
SS350GE01R29-00L	
SS350GB01R77-02J	150BMPAB01R77
SS350GE01R29-02J	
SS350GE01R31-02J	
SS350GE01R85-02J	
SS350GE03L30-02H	
SS350GE03L32-00H	
SS350GE03L32-01I	
SS350GE03L32-02G	
SS350GE03L32-02H	
SS350GE03R21-02H	
SS350GE03R25-03J-S	
SS350GE03R29-02F	
SS350GE03R29-02H	
SS350GE03R29-03I	
SS350GE03R29-03J	
SS350GE03R31-00A	
SS350GE03R31-00F	
SS350GE03R31-00G	
SS350GE03R31-00L	
SS350GE03R31-02G	
SS350GE03R31-02H	
SS350GE03R31-02L	
SS350GE03R31-03J	
SS350GE03R31-1552	
SS350GE03R31-1553	
SS350GE03R37-02H	
SS350GE03R77-02H	
SS350GE03R85-02H	150BMPAC03R85
SS350GE03R99-03I	
SS350GE01R85-02H	150BMPAC01R85

SS175/SS350 MODEL CODING

SS175 G E 03 R 31 XX 024

SIZE STARTER	ORIENTATION
GAS SEALED	SR=SPARK RESISTANT
GEAR RATIO	PINION CODING
SAE No. MOUNTING FLANGE	ROTATION L or R

SS175/SS350 Series

This chart is a condensed list of engines that can be cranked with an IR starter. For a complete list, please contact IR.

SS175/SS350 Series Engine Selection Guide

Manufacturer	Engine	CID	Liter	CYL	Type	Vane Starter
CATERPILLAR	1673	638	10.5	6	Diesel	SS175GE03R29
	3126	439	7.2	6	Diesel	SS175GB01R29
	3145	525	8.6	6	Diesel	SS175GE03R29
	D-315	350	5.7	4	Diesel	SS175GB03R31
	D-320	252	4.1	4	Diesel	SS175GB03R31
	D-330TA	350	5.7	4	Diesel	SS175GB03R31
CUMMINS	6BT5.9	359	5.9	6	Diesel	SS175GE01R071
	6BTA180	359	5.9	6	Diesel	SS175GE01R071
	V6-140	352	5.8	6	Diesel	SS175GE03R29
	V6-155	378	6.2	6	Diesel	SS175GE03R29
	ISB	359	5.9	6	Diesel	SS175GE01R071
	ISC	506	8.3	6	Diesel	SS175GE01R29
	ISL	549	9.0	6	Diesel	SS350GE03R29
	ISM	659	10.8	6	Diesel	SS350GE03R31
	N14	855	14	6	Diesel	SS350GE03R31
DETROIT DIESEL	ISX	915	15	6	Diesel	SS350GE03R31
	Series 50	519	8.5	4	Diesel	SS350GE03R31
	Series 60	778	12.7	6	Diesel	SS350GB03R31
DEUTZ-MWM	8V-2000	976	16.0	8	Diesel	SS350GB03R31
	BF6L913	374	6.1	6	Diesel	SS175GB01R77
	BF8L513	779	12.8	8	Diesel	SS350GE01R85
	F12L413	1035	17.0	12	Diesel	SS350GE01R85
	F6L413	584	9.6	6	Diesel	SS175GB01R85
M.W.M	F6L912	345	5.7	6	Diesel	SS175GB01R77
	D234	1343	22.0	12		SS350GE01R77-02J
MACK	G232V8	720	11.8	8		SS350GE01R77-02J
	END465	465	7.6	4	Diesel	SS175GE01R77
VOLVO PENTA	END475	475	7.8	4	Diesel	SS175GE01R77
	D50A	313	5.1	6	Diesel	SS175GB01R77
	D70A	410	6.7	6	Diesel	SS175GB01R77
	TAMD163	983	16.1	6	Diesel	SS175GE03R29
	TAMD71B	411	6.7	6	Diesel	SS175GE01R85
	TD100GD100	410	6.7	6	Diesel	SS175GB01R77
	TD61	334	5.5	6	Diesel	SS175GB01R77
	TMD100A	586	9.6	6	Diesel	SS175GE01R85
TMD122	731	12.0	6	Diesel	SS175GE01R85	
WAUKESHA	197DLC	302	4.9	6	Diesel	SS175GE01R29
	6SRB	677	11.1	6	Nat. Gas	SS175GE03R29
	F11G (SI)	673	11.0	6	Nat. Gas	SS350GE03R29-02H
	F18GL (D)	1096	18.0	6	Nat. Gas	SS350GE03R31
	F476D	475	7.8	6	Diesel	SS175GE01R77-02J
	H24GL (D)	1462	24.0	8L	Nat. Gas	SS350GE03R31-02H
WHITE ENGINES	D-4800	478	7.8	6	Diesel	SS175GE03R29
	DRXB	474	7.8	6	Diesel	SS175GB03R31
	DWXC	358	5.9	6	Diesel	SS175GB03R31
	HXC	779	12.8	6	Gas	SS175GE03R29



SS175/SS350 Series Air Starters

SS175/SS350 Series Genuine Ingersoll-Rand Replacement Kits:

Tune Up Kit Part Number	Description
SS175-TK2	SS175 Tune Up Kit
SS350-TK2	SS350 Tune Up Kit

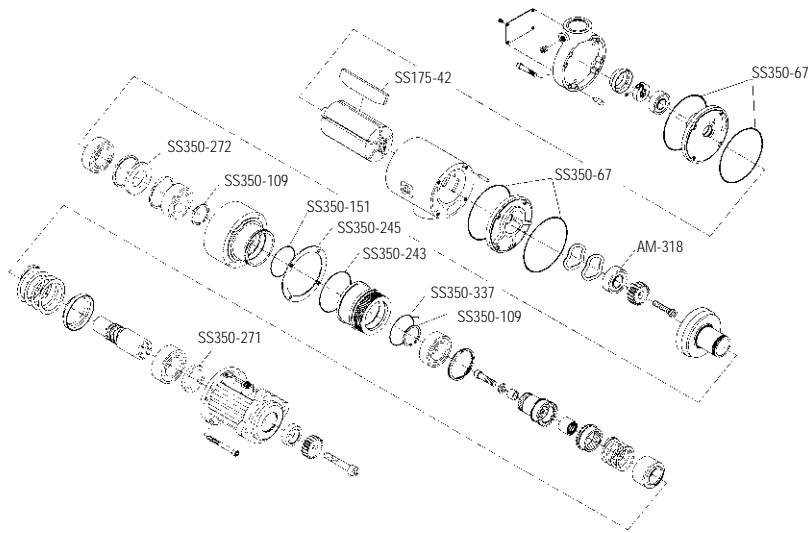

Exploded View of SS175-TK2 Part Location



SS175-TK2 Parts

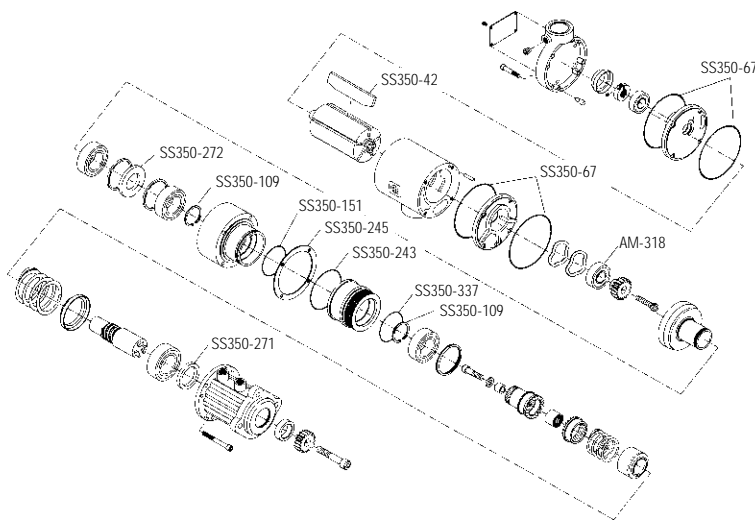

Exploded View of SS350-TK2 Part Location



SS350-TK2 Parts