



## Air Starters

# SS800 Series



**For engine displacement of:** Diesel-1000 to 20,000 CID (16 to 320 liters)  
Carburated-2000 to 40,000 CID (32 to 640 liters)

### Features/Benefits

- All models sealed for use in air or gas applications
- Offset design for simple mounting
- Powerful 80 hp motor
- Multiple offset gear ratios: B = 2.18:1  
C = 2.53:1  
D = 3.44:1
- Backcap ports for injection lubricating

### Versatile

- Inertia and pre-engaged drives available
- 4 inlet, 4 exhaust, and 16 drive housing orientations
- 90-150 psi operation
- Remanufactured starters available
- Left- and right-hand rotation available



*IR's genuine SS810GB03R31 inertia remanufactured starter is shown mounted on a Detroit Diesel 16V-71R.*



*The SS815GB03R31 starter is shown mounted on a Cummins KTA50-M2 piped with the IR SRV150 Relay Valve.*



## SS810G Series DIMENSIONS

Weight lbs (kg)	
SS810G	93 (42.2)

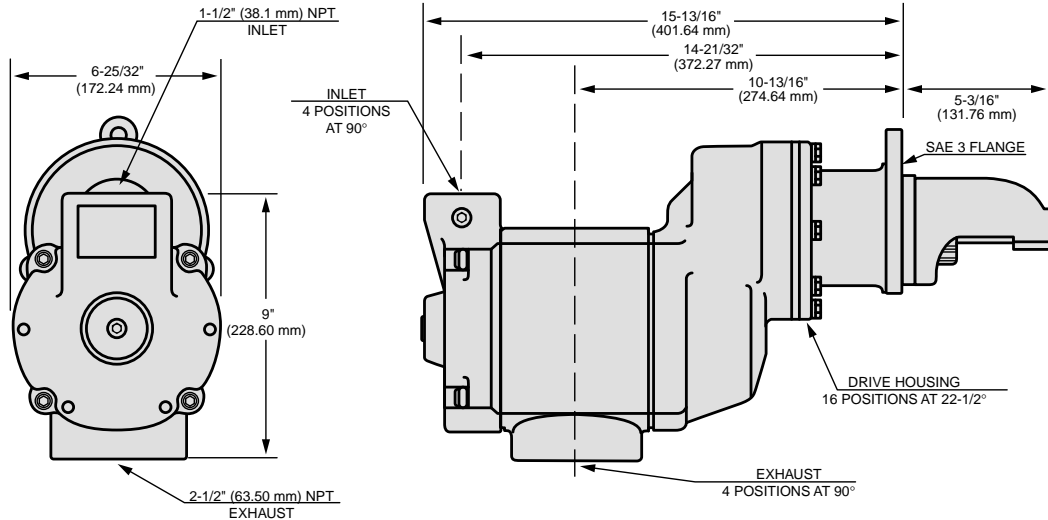

## SS815G and SS825G Series DIMENSIONS

Weight lbs (kg)	
SS815G	93 (42.2)
SS825G	95 (43.1)

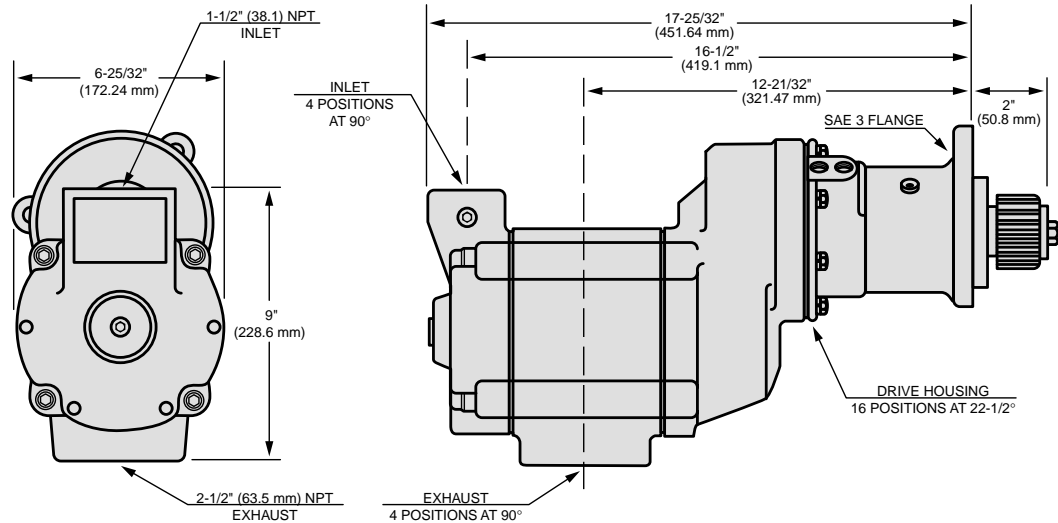

## SS850G Series DIMENSIONS

Weight lbs (kg)	
SS850G	123 (55.8)

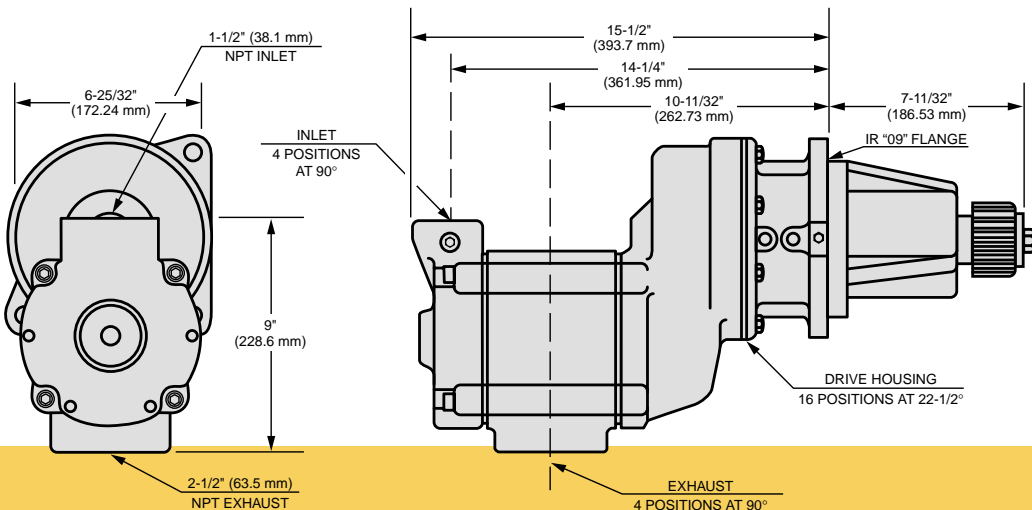

# SS800 Series

## SS810 and SS815 Series Performance Information

Pressure PSI (bar)	Breakaway Torque ft-lb (Nm)	Speed @ Max HP RPM	Max HP	Flow @ Max HP SCFM (L/s)
90 (6.2)	170 (230)	2700	45	1100 (519)
120 (8.3)	205 (278)	2800	58	1250 (590)
150 (10.3)	250 (339)	3200	80	1700 (802)

## SS825 Series Performance Information

Pressure PSI (bar)	Breakaway Torque ft-lb (Nm)	Speed @ Max HP RPM	Max HP	Flow @ Max HP SCFM (L/s)
90 (6.2)	200 (271)	2300	45	900 (425)
120 (8.3)	240 (325)	2400	58	1100 (519)
150 (10.3)	300 (407)	2700	75	1350 (637)

## SS850 Series Performance Information

Pressure PSI (bar)	Breakaway Torque ft-lb (Nm)	Speed @ Max HP RPM	Max HP	Flow @ Max HP SCFM (L/s)
90 (6.2)	260 (352)	1600	45	800 (378)
120 (8.3)	340 (461)	1800	58	1000 (472)
150 (10.3)	415 (562)	1900	75	1275 (602)









## SS800 Series Number of Starts per Tank

(Assuming 2-Second Crank Time @ 90 PSI)

300	5	6	7	8	10	11	12	13	20	Max Tank Pressure (psi)	Max Tank Pressure (bar)		
270	4	5	6	7	8	10	11	12	18				
240	4	5	5	6	7	8	9	10	16				
210	3	4	5	5	6	7	8	8	14				
180	2	3	4	4	5	5	6	7	12				
150	2	2	3	3	4	4	5	5	10				
120	1	2	2	2	2	3	3	3	8				
90	1	1	1	1	1	1	2	2	6				
	80	100	120	140	160	180	200	220					
	302	378	454	529	605	680	756	832					Gallons Liters
	<b>Tank Size</b>												

## SS800 Series Accessories

See catalog pages I-1 to I-20 for detailed Accessory information.

IR Part #	Description	Picture
1 SS800-A674	2-1/2" Muffler	
2 150BMP-1051B	1/4"12 V Solenoid Valve	
3 150BMP-2451B	1/4" 24 V Solenoid Valve	
4 NL-24-8	In-Line Lubricator	
5 HDL2 (Stationary)	3/8" NPT Lubricator (1.3 cc)	
6 HDL3 (Transportation)	3/8" NPT Lubricator (0.4 cc)	
7 SMB-618	Push Button Valve	
8 SMB-G618	Gas Rated Push Button Valve	

IR Part #	Description	Picture
9 SRV150	1-1/2" Relay Valve For Air Applications	
10 SRV150SS	1-1/2" Gas Rated Relay Valve	
11 150BMP-1058	Gladhand	
12 150BMP-1064	1/8", 150 psi Pressure Gauge	
13 ST900-267-24	1-1/2" Strainer (300 Mesh)	
14 ST900-267-32	2" Strainer (300 Mesh)	
15 ST900-266-24	1-1/2" Strainer Element (300 Mesh)	
16 ST900-266-32	2" Strainer Element (300 Mesh)	

Red item numbers correspond to numbers in diagrams on page G-5.

# SS800 Series

## SS810 Typical Stationary Installation

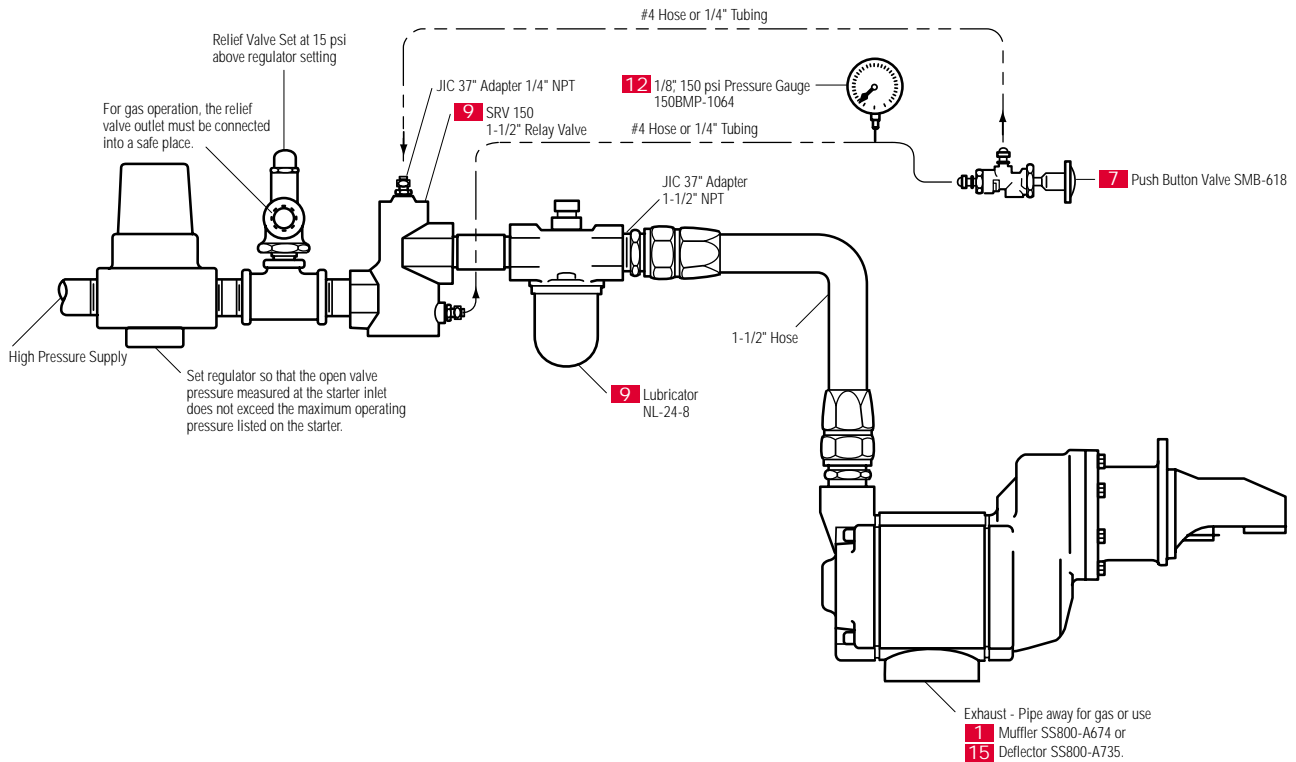

## SS815/SS825/SS850 Typical Stationary Installation

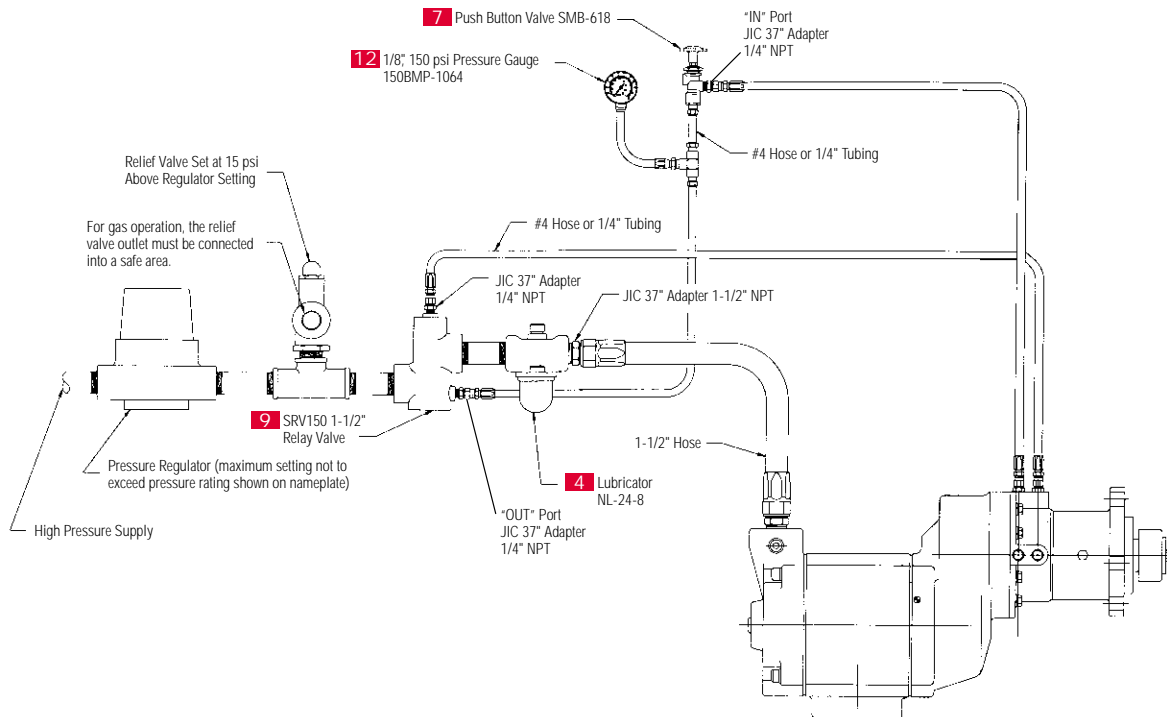

# Air Starters

**Bold Model Numbers** indicate that a remanufactured model is available with the same part number (Add an "R" to the number).

**Most Obsolete Units** ▶

## SS800 Crossover Model Numbers

SS800 Series Available Units	SS800 Obsolete Units	SS660 Obsolete Units	SM450 Obsolete Units	20BM Obsolete Units
<b>SS810GB03L32</b>	SS800GB03L32	SS660LB991A02	SM450LB991A02	20BMB47LH-4
<b>SS810GB03R31</b>		SS660RB991A01	SM450RB991A01	20BMB41RH-1
SS810GB03R31-02M-F				
SS810GB03R31-13B				
SS810GB03R31-13C				
SS810GB03R31-310				
SS810GB03R31-31A				
SS810GB03R31-31P				
SS815FGB03L32				
<b>SS815FGB03R31</b>				
<b>SS815GB03L32</b>	SS800GB03L32	SS660LB991A02	SM450LB991A02	20BMB47LH-4
SS815GB03L32-02G				
SS815GB03L32-22H				
SS815GB03L92-1738				
<b>SS815GB03R25R</b>				
<b>SS815GB03R31</b>				
SS815GB03R31-02B				
SS815GB03R31-02G				
SS815GB03R31-02H				
SS815GB03R31-02K				
SS815GB03R31-11C				
SS815GB03R31-12G				
SS815GB03R31-1323	SS800BR/VRSM-962			
SS815GB03R31-21G				
SS815GB03R31-220				
SS815GB03R31-23C				
SS815GB03R31-23D				
SS815GB03R31-23K				
SS815GB03R31-310				
SS815GB03R91	SS800GB03R91	SS660RB991A08		
SS815GBDPI3R493				
SS825FGC03L26				
<b>SS825FGC03R25</b>				
<b>SS825GC03L26</b>		SS660LB981A04	SM450LB981A04	20BM21LH-22
SS825GC03L26-1162				
SS825GC03L26-1163				
SS825GC03L26-11E				
SS825GC03L52-21C				
SS825GC03L52-23E				
<b>SS825GC03R25</b>		SS660RB981A03	SM450RB981A03	20BMB21RH-19
SS825GC03R25-02K				
SS825GC03R25-21G				
SS825GC03R25-310				
SS825GC03R25-31D				
SS825GC03R25SR-02G				
SS825GC03R31				
SS850GD09L52		SS660LD971A06	SM450LD971A06	20BMD52LH-26
SS850GD09R51		SS660RD971A05	SM450RD971A05	20BMD52RH-25

### SS800 SERIES MODEL CODING

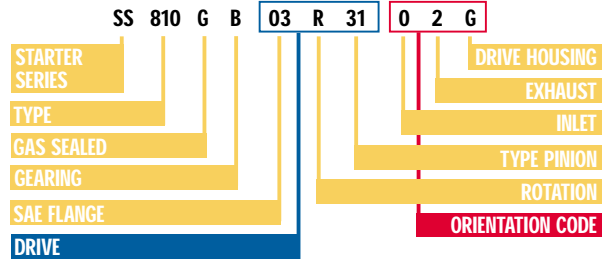

# SS800 Series

*This chart is a condensed list of engines that can be cranked with an IR starter. For a complete list, please contact IR.*

## SS800 Series Engine Selection Guide

Manufacturer	Engine	CID	Liter	CYL	Type	Vane Starter
CATERPILLAR	3412	1649	27.0	12	Diesel	SS815GB03R31
	3512	3158	51.8	12	Diesel	SS815GB03R31
	3516	4210	69.0	16	Diesel	SS815GB03R31
	G3612	13527	221.7	12	Nat. Gas	SS815GB03R31
	G3616	18036	295.6	16	Nat. Gas	2 - SS815GB03R31
	G-398	2946	48.3	12	Nat. Gas	SS815GB03R31
	G-399	3927	64.4	16	Nat. Gas	SS815GB03R31
CES-BESSEMER	GMXE	9420	154.0	12	Nat. Gas	SS850GD09L52
	GMXF	9420	154.0	12	Nat. Gas	SS850GD09L52
	GMXH	9420	154.4	12	Nat. Gas	SS850GD09L52
CUMMINS	K19 SERIES	1150	18.8	6	Diesel	SS815GB03R31
	K38 SERIES	2300	37.7	12	Diesel	SS815GB03R31
	K50 SERIES	3067	50.3	16	Diesel	SS825GC03R31
	QSK45	2746	45.0	12	Diesel	SS815GB03R31
	QST30	1861	30.0	12	Diesel	SS815GB03R31
	VT28	1710	28.0	12	Diesel	SS815GB03R31
	VTA28-C	1710	28.0	12	Diesel	SS815GB03R31
Detroit Diesel	12V-92	1104	18.1	12	Diesel	SS815GB03R31
	16V-149	2384	39.1	16	Diesel	SS815GB03R31
	16V-71	1136	18.6	16	Diesel	SS815GB03R31
	16V-92	1472	24.1	16	Diesel	SS815GB03R31
	12V4000	2928	48	12	Diesel	SS815GB03R31
	16V4000	3904	64	16	Diesel	SS815GB03R31
EMD GM	12-278	6809	111.6	12	Diesel	SS850GD09R51
	12-498	7576	124.1	12	Diesel	SS850GD09R51
WAUKESHA	7044	7040	116.0	12V	Nat. Gas	SS815GB03R31
	12VAT25D	10784	176.7	12	Diesel	SS825GC03R25
	12VAT27	17397	285.0	16	Diesel	SS825GC03R25
	12VAT27GL	13048	214.0	12V	Nat. Gas	SS825GC03R25
	16AT27GL	17397	285.0	16	Nat. Gas	SS825GC03R25
	16VAT25GL	14378	235.6	16	Nat. Gas	SS825GC03R25
	7042G (SI/L)	7040	115.0	12V	Nat. Gas	SS815GB03R31
	8LAT25D	7189	117.8	8	Nat. Gas	SS815GB03R31
	8LAT25GL	7189	117.8	8	Nat. Gas	SS815GB03R31
	8LAT27GL	8699	143.0	8	Diesel	SS815GB03R31
	F1197D	1197	19.6	6	Diesel	SS815GB03R31
	F1905D	1905	31.2	6	Diesel	SS815GB03R31
	F2895G (SI)	2894	47.4	6	Nat. Gas	SS815GB03R31
	F2896D	2894	47.4	6	Diesel	SS815GB03R31
	F3335D	3335	54.7	6	Diesel	SS815GB03R31
	F3336D	3335	54.7	6	Diesel	SS815GB03R31
	F3521G (SI)	3520	58.0	6L	Nat. Gas	SS815GB03R31
	L5788D	5788	94.8	12	Diesel	SS825GC03R25
	L5792D	5788	94.8	12	Diesel	SS825GC03R25
	P9390G	9388	154.0	16	Nat. Gas	SS825GC03R25





# SS800 Series Air Starters

## SS800 Series Genuine Ingersoll-Rand Replacement Kits:

Tune Up Kit Part Number	Description
SS800-TK2	SS815 and SS825 Tune Up Kit
SS810-TK2	SS810 Tune Up Kit
SS850-TK2	SS850 Tune Up Kit

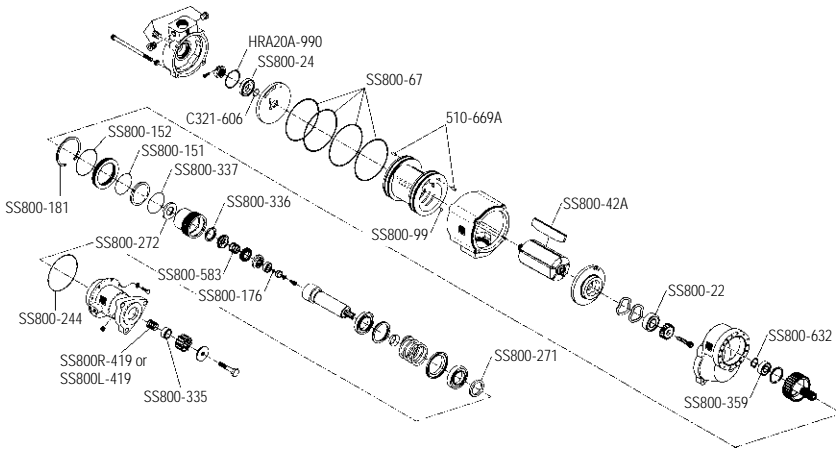

Exploded View of SS800-TK2 Part Location



SS800-TK2 Parts

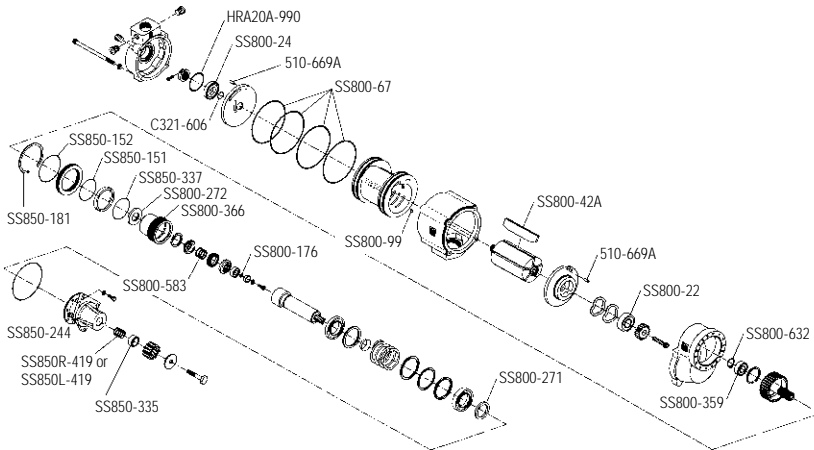

Exploded View of SS850-TK2 Part Location

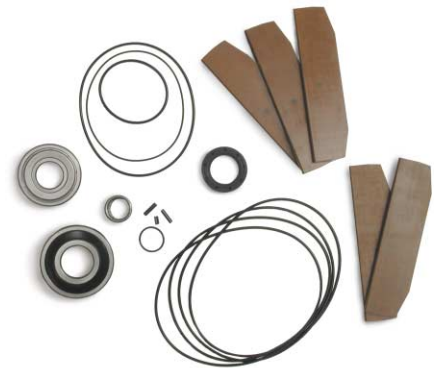

SS810-TK2 Parts